



M12 CLLP

SERVICE PARTS DIAGRAM

TTI Model Number: 006 912 604

M12™ CROSS LINE AND PLUMB POINT LASER LEVEL

Bulletin Date:

Jan-21

Starting Serial Number:

VERSION A -

EXAMPLE:
00 0
Component Parts (Small #)
Are Included When Ordering
The Assembly (Large #).

Inspect sticker applied to the face of the Magnet (1). Orient the Magnet and Steel Strap (2) so that the "N/S" faces in the upward direction relative to the tool. The left (L) is inserted into the left side of the bracket and the right (R) magnet is inserted into the right side. Insert the Magnet and Steel Strap into the mount so that the post aligns with the inner diameter on the magnet. After the Magnet and Steel Strap is inserted into the mount, the sticker can be removed and the screws (3) can be hand tightened. Do not over tighten.

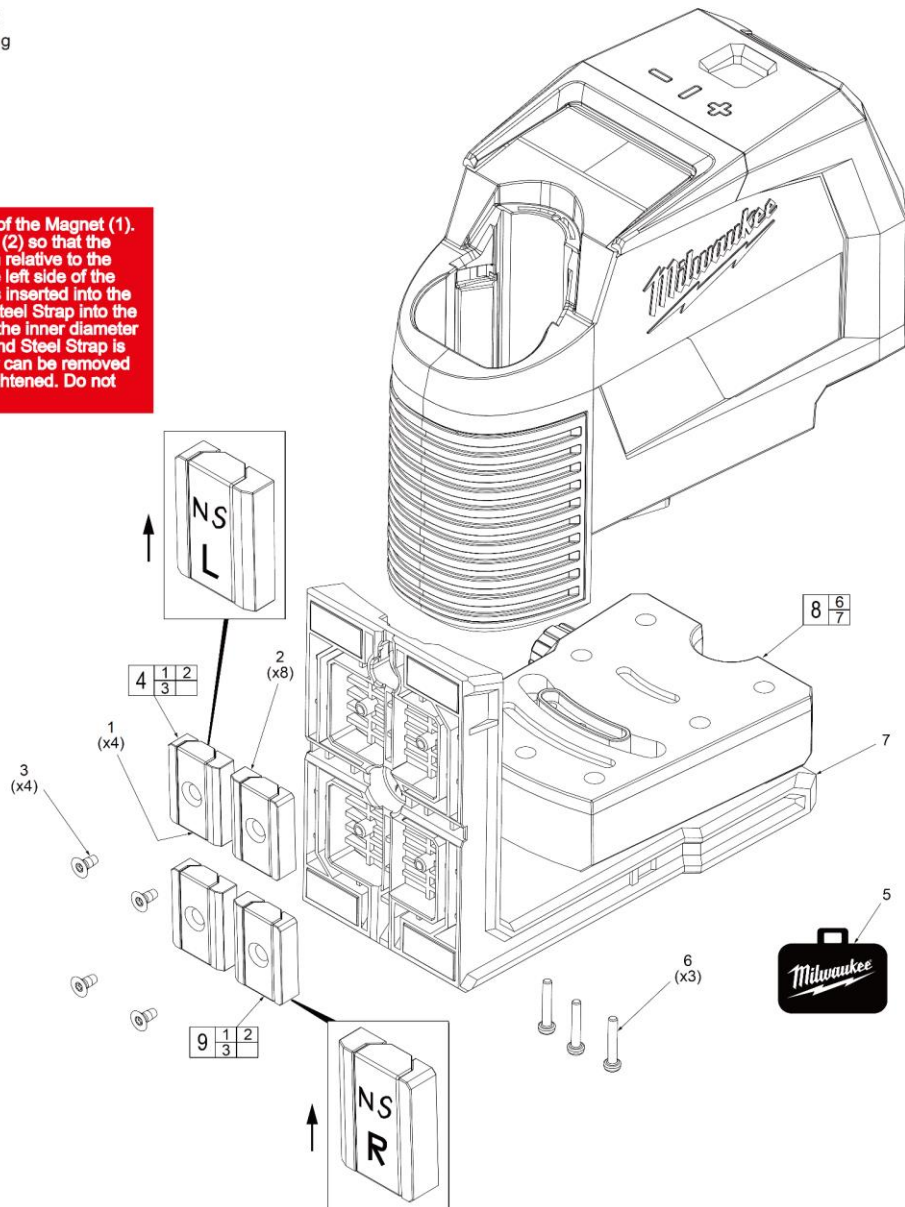

FIG. NOTES

10

A clean, dry surface is essential for proper performance for any adhesive system. The area intended for application of any adhesive label or nameplate must be prepared by cleaning with isopropyl alcohol. The solvent is to be applied with a clean, lint free applicator and the surface allowed to dry before applying the label or name plate.



M12 CLLP

SERVICE PARTS LIST

TTI Model Number: 006 912 604

M12™ CROSS LINE AND PLUMB POINT LASER LEVEL

Bulletin Date:

Jan-21

Starting Serial Number:

VERSION A -

ITEM	PART NUMBER	PART DESCRIPTION	QTY (PCS)
1	-	MAGNET	4
2	-	STEEL STRAP	8
3	-	M2.5X6MM FH ST T10 SCREW	4
4	006912602001	M12 LASER MAGNET ASSY / LEFT / SERVICE KIT	2
5	006912602004	M12 CROSS PT LASER BMC / SERVICE KIT	1
6	-	ST SCREW/TOREX RECESS ST2.5X15	3
7	-	MOUNT ASSEMBLY	1
8	006912602003	M12 CROSS PT LASER MOUNT ASSY / SERVICE KIT	1
9	006912602002	M12 LASER MAGNET ASSY / RIGHT / SERVICE KIT	2
10	00698000321K1	RATING LABEL (NOT SHOWN)	1